



AIR-CHIEF

STANDARD FEATURES:

- 20" Wide Soft Seat Cushion
- Height Adjustable Headrest (*can be removed*)
- Fully Reclining Backrest
- Triple Chamber Air-Lumbar Support System
- 3-Position Seat Cushion Extension & Tilt Adjustment
- Fore & Aft Slides (7 Inch Tracks)
- Poly-Dynamic Air-Suspension™
- Integrated Isolator
- ICP - moves with Suspension & Isolator
- Bellow



Optional:

FAS

(Foam Adjustment System)

Helps adjust the contours of the foam to the body's natural curvature.

FAS system includes:

Triple chamber air-lumbar support system to adjust the proper posterior pelvic tilt, which is important for proper posture.

Dual chamber side bolster support system. It allows to adjust the width of the seat back, and control the amount of support on each side of the body.

Part # shown: 98CH-L82MH0S15
+ 730147-000 Pro Box
+ 731153-000 Heat

CONTACT US AT:
INFO@KNOEDLER.COM
TEL: 450-445-4777

WWW.KNOEDLER.COM



Air-Chief Part Numbers

DESCRIPTION	PART NUMBER									
Standard (bellow, isolator, headrest)	98	C	H	-	S	72	MH	0	X	01
Add ProBax System	12									
Add FAS				-	L					
Add FAS and lower seat by 2"		L	R	-	L					
Increase Cushion width to 23" (Not available with ProBax)			W							
Add arms						82				
Remove headrest							MB			
Add heat								H		
Matrix									X	
Mordura										D
Synthetic Leather										S
Genuine Leather										L
Black										01
Brown										02
Tan										03
Gray										05
Red										06
Black/Brown										12
Black/Tan										13
Black/Gray										15
Black/Red										16
Add Options:										
ProBax Kit	730147-000									
Massage	730113-000									
Memory Foam	731152-000									
Heat	730130-000									
Heat & Cool	730114-000									
Swivel (pneumatic)	731153-000									



O P T I O N S

My name is Kay Lameyer, and my husband Jim and I are the owners of Blue Thunder Trucking. You might not remember us, but we have never forgotten you.

A little over two years ago, we were working with our Kenworth T800 Tandem Dump Truck in our hometown of Colorado Springs, CO. We were considering closing our business because Jim was in so much pain. His head, back and knee hurt daily. We tried everything from therapy, exercise, and medication. We even moved to the Arizona/Nevada area hoping the warm climate would help him.

The real answer came for us after we attended the 2006 Truck Show in Las Vegas, NV. Knoedler Manufacturers had their seats on display. They told us about the quality and craftsmanship of a Knoedler seat, and we purchased The Chief seat after the show.

This was the best investment we ever made. The seat was installed in half an hour, and Jim noticed the difference immediately. He has felt incredible relief since the first day. Blue Thunder is a strong company again, and Jim tells everyone about his Knoedler seat. We want everyone to know why it is the best seat in America, and what a difference it has made in our lives.

**Swivel Kit Remote Actuating
(excluding Slides)
Part #: 731153-000**

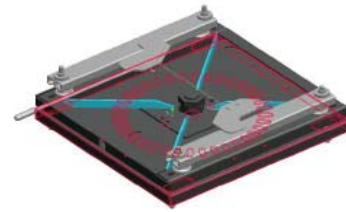

**HD-Suspension Upgrade
Part #: 730148-000**



**Massage System Kit
8-Motors
Part #: 730113-000**



**Memory Foam Kit
(Can not be combined with
HEAT and HEAT & COOL
Systems)
Part #: 731152-000**



**Standard Seat fits all Legacy Kenworth & Peterbilt Models.
Most Freightliner Trucks**

**International Adaptor:
Part #: RR07-INTER-000**

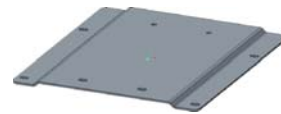

**Volvo Trucks Adaptor
Part #:RR00-22VO-000**



**Freightliner EZ Rider Adaptor
Part #: RR12-FL01-000**



**Kenworth & Peterbilt New
2.1 Meter Cab Adaptor
Part #: RR15-KWPB-000**



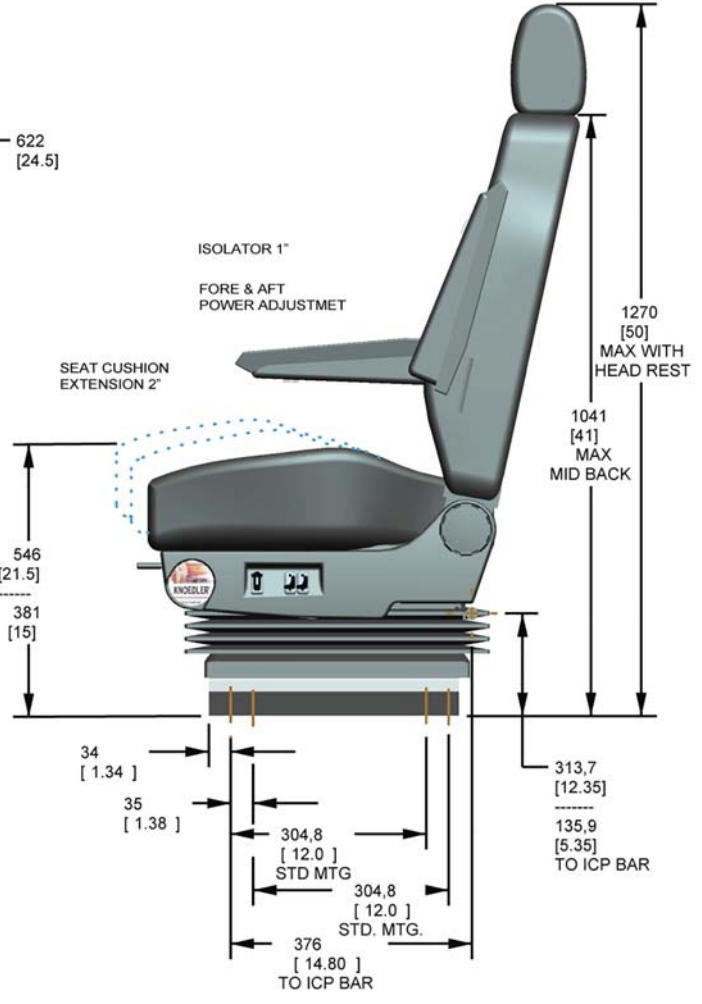
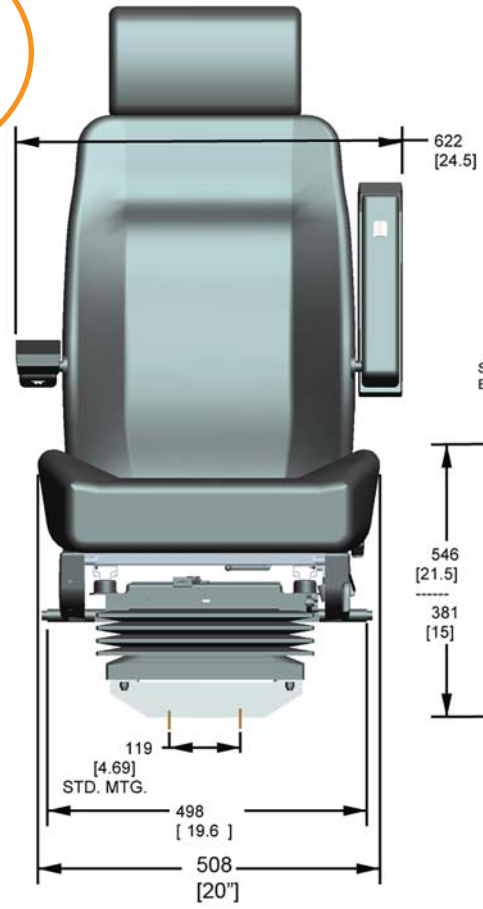

NOTE:
If you opted for the 2" lower seat, then subtract 2" from the height dimensions shown above.

NOTE: It is the responsibility of the installer to determine the suitability for use of this product in each application. The drawings are for reference purpose only

WARNING: Serious injury may occur if head clearance is not adequate. After installing seat and before riding or driving the vehicle, ensure there is adequate head clearance at maximum upward travel of seat. In order to reach the highest position of the seat, while sitting in seat, slowly raise the seat to its maximum height by actuating the suspension air control valve.

