

KNOEDLER®

MANUFACTURIÈRS CANADA, LTEE

EXTREME LOW-RIDER

STANDARD FEATURES:

- 20" Wide Seat Cushion
- Mid Back with adjustable Headrest
- Arms Front Adjustable (Optional)
- Triple Chamber Air-Lumbar Support System
- FAS (Foam Adjustment System) (Optional)
- Fore & Aft Slides (7")
- Extra Low Profile
- Poly-Dynamic Air-Suspension™ (3.5" Stroke)
- Integrated Isolator (optional)
- Integrated 12V or 24V Compressor

Optional:

FAS system includes:

Triple chamber air-lumbar support system to adjust the posterior pelvic tilt, which is important for proper posture.

Dual chamber side bolster support system. Allows for adjustment of the side bolsters to provide lateral support.



Part # shown:98SC-L62MH0S01



CONTACT US AT:
INFO@KNOEDLER.COM
TEL: 450-445-4777

WWW.KNOEDLER.COM

Ex-Lo Part Numbers

DESCRIPTION	PART NUMBER										
	98	S	C	-	S	5	0		0	X	01
Standard Mid Back & Headrest											
Add Isolator							2				
Add Integrated Compressor			S								
Add FAS				-	L						
Add arms						6					
Mid Back & Head Rest											
Remove headrest											
Add heat									H		
Matrix										X	
Mordura										D	
Synthetic Leather										S	
Genuine Leather										L	
Black											01
Brown											02
Tan											03
Gray											05
Red											06
Black/Brown											12
Black/Tan											13
Black/Gray											15
Black/Red											16
Add Options:											
ProBax Kit	730147-000										
Massage	730113-000										
Memory Foam	731152-000										
Heat	730130-000										
Heat & Cool	730114-000										



O P T I O N S

My name is Kay Lameyer, and my husband Jim and I are the owners of Blue Thunder Trucking. You might not remember us, but we have never forgotten you.

A little over two years ago, we were working with our Kenworth T800 Tandem Dump Truck in our hometown of Colorado Springs, CO. We were considering closing our business because Jim was in so much pain. His head, back and knee hurt daily. We tried everything from therapy, exercise, and medication. We even moved to the Arizona/Nevada area hoping the warm climate would help him.

The real answer came for us after we attended the 2006 Truck Show in Las Vegas, NV. Knoedler Manufacturers had their seats on display. They told us about the quality and craftsmanship of a Knoedler seat, and we purchased The Chief seat after the show.

This was the best investment we ever made. The seat was installed in half an hour, and Jim noticed the difference immediately. He has felt incredible relief since the first day. Blue Thunder is a strong company again, and Jim tells

Massage System Kit
8-Motors
Part #: 730113-000



Memory Foam Kit
Part #: 731152-000



ADD 1" Riser/Adaptor to Fit Most Std Trucks and all Legacy Kenworth & Peterbilt Models. Most Freightliner Trucks

1" Riser/Adaptor:
Part #: RR00-1000-000

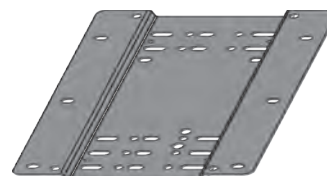

Special adapters to fit special makes.(see below)
- made for customer requests (not tested validated by Knoedler):
(Installer is responsible to verify fit & suitability of adapter and seat in vehicle)

Sprinter (original-seat non Swivel)	Part #: RR13-MB01-000
Sprinter (original-seat with Swivel)	Part #: RR13-MB01-001
Ford F-Series	Part #: RR10-FORD-000
Dodge RAM	Part #: RR17-DODGE-000
Chevy/GMC	Part #: RR09-GMC45/55-000
Isuzu N-Series 1996 - 2007	Part #: RR05-IS00-000
Isuzu N-Series 2008 - New	Part #: RR05-IS00-001
Fuso	Part #: RR11-IS01-000
Hino 195	Part#: RR18-HINO195-000
Topkick/Kodiak	Part#: RR04-TK00-000
Freightliner M2 Business Class	Part#: RR03-BC00-000

KNOEDLER
MANUFACTURIERS CANADA, LTEE

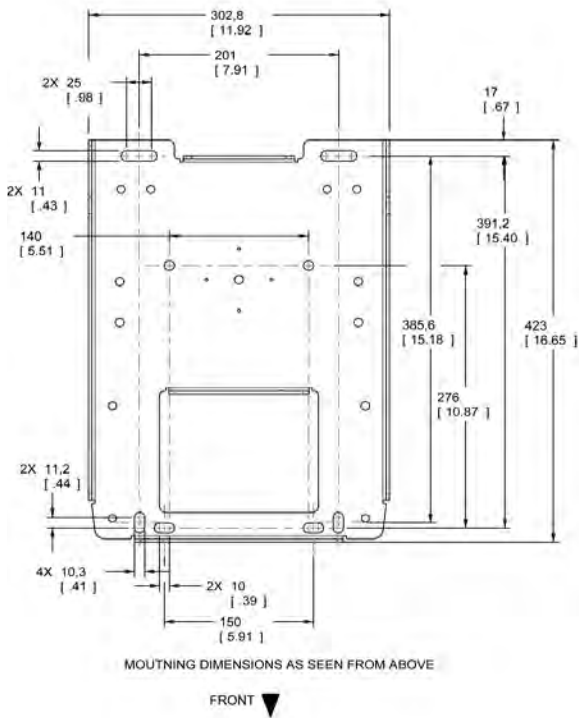

Optional: 1" High adaptor Riser to fit most Truck Makes

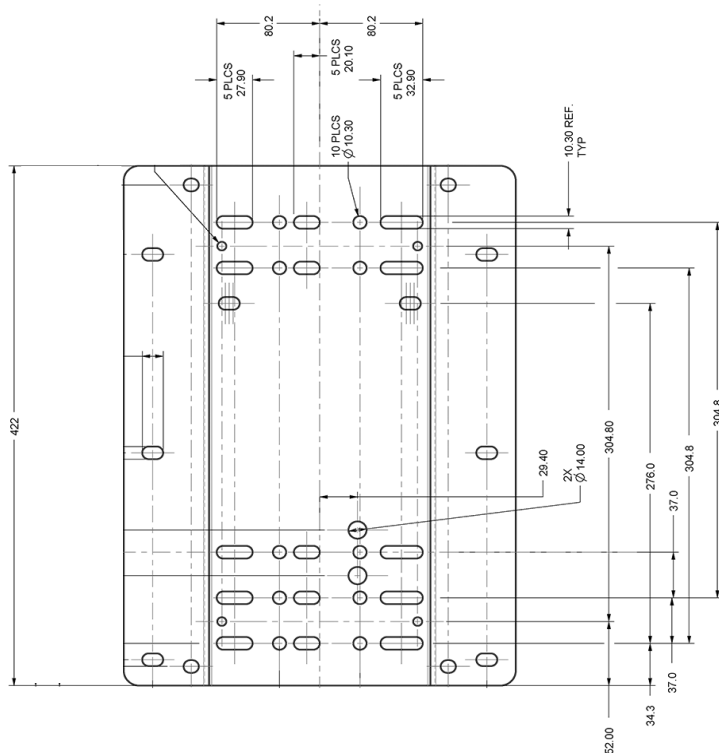

Note: Max values are shown with 3.5" suspension Stroke. If suspension stroke is higher or different: then values shown here need to be adjusted accordingly.

WARNING: It is the responsibility of the installer to determine the suitability for use of this product in each application. Any drawings shown in this document are for reference purpose only.

The installer is responsible to ensure that proper seat mounting hardware and mounting channels (when required) and seat belt and tether belt anchorages are used according to requirements of the Federal motor vehicle safety standards. Use only high strength fasteners and heavy duty washers and tether belts when installing the seat assembly.

WARNING: Serious injury may occur if head clearance is not adequate. After installing seat and before riding or driving the vehicle, ensure there is adequate head clearance at maximum upward travel of seat.

In order to reach the highest position of the seat, while sitting in seat, slowly raise the seat to its maximum height by actuating the suspension air control valve.

WARNING: This seat has been tested on a flat floor and conforms to Federal Motor Vehicle safety standards (FMVSS) 207 and 302 at time of manufacture using correct hardware and tether belt mounting.

WARNING: Seat belts need to be worn at all times when operating a vehicle.

WARNING: Injury or damage to the seat may occur if seat and seat suspension are not kept free of interference of objects near or around the seat; if not kept free of debris or foreign material.