

AIR-CHIEF

Mechanical Seat

Standard Features:

- Seat with Dual Suspension Systems:
 - o Low-Profile Suspension integrated in Seat Upper
 - 1.5" suspension stroke
 - o Mechanical Suspension system
 - 5" tall suspension (2.5" stroke)
 - Both systems adjust to weight between (110lbs - 264lbs)
 - o Foam in Place, moisture-wicking
 - o Document Pouch
 - o Backrest Angle (0- 8 Degrees)
 - o 17" Wide Cushion
 - o 6" Fore / Aft Position Adjustment
 - o Rubber Bellow

Options:

- Armrests:
 - 731061-000 - Left Hand armrest
 - 731062-000 - Right Hand armrest
- Hip Guards
 - 730129-000 - Hip Guard Kit



Part # Shown: 800092-000
+ Option of Hip Guards (730129-000)

www.knoedler.com

Customer Service: 450-445-4777 - Fax: 450-445-0086

AIR-CHIEF

Mechanical Seat

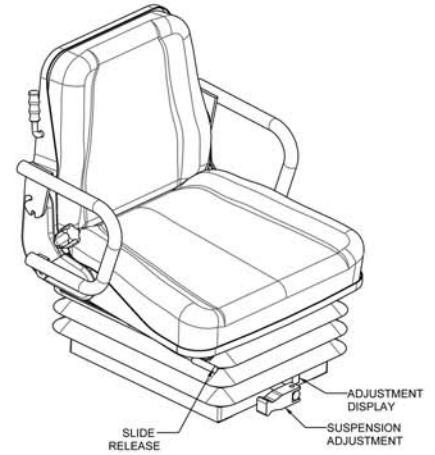

Mechanical Suspension System:

- o Mountable in most off road vehicles, no air supply or electric connections required.
- o Suspension performance can be optimized to individual operators.
- o Standardized Rubber Bellow minimizes debris in the suspension environment.
- o Easy mounting.

Other Advantages are:

- o Compact System
- o The backrest can be adjusted
- o Foam in place, the upholstery has no seams, and hence the seat will not absorb water. Once the seat cushion is whipped dry, it will be dry to sit on.
- o Easy Mounting.

